

HTGR Technology Course for the Nuclear Regulatory Commission

May 24 – 27, 2010

Module 12

Instrumentation and Controls (I&C) and Control Room Design

**Dale Pfremmer
General Atomics**

OUTLINE

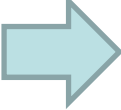
- 
- **Control and protection systems included in I&C**
 - **Reactor and process control in HTGR plant designs**
 - **Application of digital systems to monitoring, control, and protection equipment**
 - **Reactor protection developed in previous HTGR plants**
 - I&C protection system functions and protection hardware interfaces
 - Reliability and interpretation of regulatory criteria
 - **Control Room and I&C architecture preferred for overall operation of the HTGR and associated heat utilization processes**

Three Specific Systems in the HTGR System Structure Define Instrumentation and Control (I&C)

- **Plant Control, Data, and Instrumentation System (PCDIS)**
 - Provides overall plant control
 - Includes architecture which combines I&C systems and the control room equipment
- **Investment Protection System (IPS)**
 - Initiates back-up cooling to protect reactor equipment in events which could reduce service life or cause a long-term outage
- **Reactor Protection System (RPS)**
 - Initiates reactor trip to protect against nuclear control failure or loss of primary coolant from the primary reactor system

Good Plant Operability Relies Strongly on the Overall PCDIS Design Objectives

- **First, the PCDIS provides complete monitoring and control of the reactor and plant processes**
 - Includes all phases of plant operation. Startup, power operation, shutdown, etc.
 - Includes all levels of control - automatic, manual, etc.
- **Second, the PCDIS provides first-line reactor cooling to minimize standby cooling utilization and enhance operability**
- **Third, necessary packaging of all I&C functions, as accomplished through the architecture, must compliment development of a human-machine interface suited to plant operability and safety**

Assets Required to Develop the I&C Design

- **Documentation** — overall high level plant design spec, plus specific system documentation within the I&C systems and interfacing systems
- **Staffing resources** — analytical, instrumentation, administrative, procurement and other disciplines
 - I&C necessarily involves multiple contractors, increasing the documentation, personnel, etc.
- **Facilities and I&C development resources**
 - computer analysis and real-time simulator development are required
 - component selection and design verification and validation require testing
 - I&C software requires V&V

A Variety of Analysis Efforts are Required to Develop Control and Protection Hardware and Software

- **Performance analysis is needed to establish control stability margins, develop algorithms, and establish setpoints for control and protection equipment**
- **Real-time simulator analysis is needed to develop operator interface features and assure proper Human-Machine Interface (HMI) design**
- **Failure effects and reliability analysis needed to verify reliability**
- **Testing/qualification analysis needed to select equipment, verify designs, and assure implementation of design features**

OUTLINE

- Control and protection systems included in I&C
- ➔ • Reactor and process control in HTGR plant designs
- Application of digital systems to monitoring, control, and protection equipment
- Reactor protection developed in previous HTGR plants
 - I&C protection system functions and protection hardware interfaces
 - Reliability and interpretation of regulatory criteria
- Control Room and I&C architecture preferred for overall operation of the HTGR and associated heat utilization processes

The Basic HTGR Control Strategy Incorporates Process Measurements with Reactor Power Control

- A process feedback measurement which encompasses reactor heat available to the process, including stored reactor heat, is selected to perform error-based command of reactor power
 - The reactor power control issues on-off, in-out commands to the control rod stepping motors
- **Primary flow rate is controlled in proportion to plant output (electric output, etc.)**
 - Secondary flow rate (steam generator feedwater flow) control is similar
- **Reactor power responds to plant output change through the feedback mechanism**

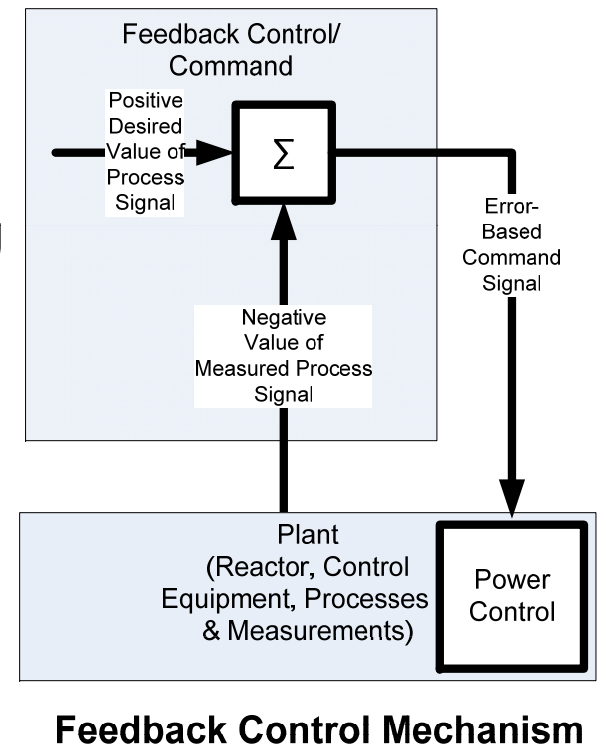

A Consistent Reactor/Process Control Strategy Has Been Used in HTGR Plant Designs

HTGR Plant Type	Feedback Measurement and Command Action			
	Nuclear Flux	Reactor Exit Temp	Steam Gen Exit Temp	Helium Flow Rate
Single reactor/ steam-electric	Control Rod Drive command	-	Reactor power level command	Circulator speed command
Multi-reactor/ steam-electric	Control Rod Drive command	-	Reactor power level command	Circulator speed command
Gas-Turbine/ electric	Control Rod Drive command	Reactor power level command	-	Inventory/ bypass command

Reactor Control Capabilities Were Established in Previous Steam-Electric or Other Plant Designs

- **Electric plant load-following — identified by requirements such as rapid load change at 5% per minute, daily load cycle frequency control, and $\pm 10\%$ load step changes — is achievable and can be incorporated in the I&C design**
 - Steam supply temperature can be held within $\pm 3^\circ \text{C}$ to maintain high plant efficiency at lowered power
 - Reactor component and fuel temperatures can be maintained well within normal operating levels
 - Transient nuclear power advance is completely tolerable
- **Reduction of reactor power following electric load rejection, as in the GT-MHR electric plant, requires even faster power transitions**

Several Major Feedback Control Systems are Typical in HTGR Plants Producing Steam Power

- **Main steam temperature in command of reactor power**
- **Reactor power in command of neutron control assembly (NCA) hardware**
- **Circulator flow rate in command of circulator speed control hardware**
- **Feedwater flow rate in command of feedwater pump speed control hardware**
- **Main steam pressure in command of steam throttle-valve hardware**
- **Main steam de-superheat temperature - startup and shutdown main steam temperature control**
- **Reactor inlet temperature in command of feedwater holding tank pressure control valve hardware**

Typical HTGR Steam-Electric Plant Control

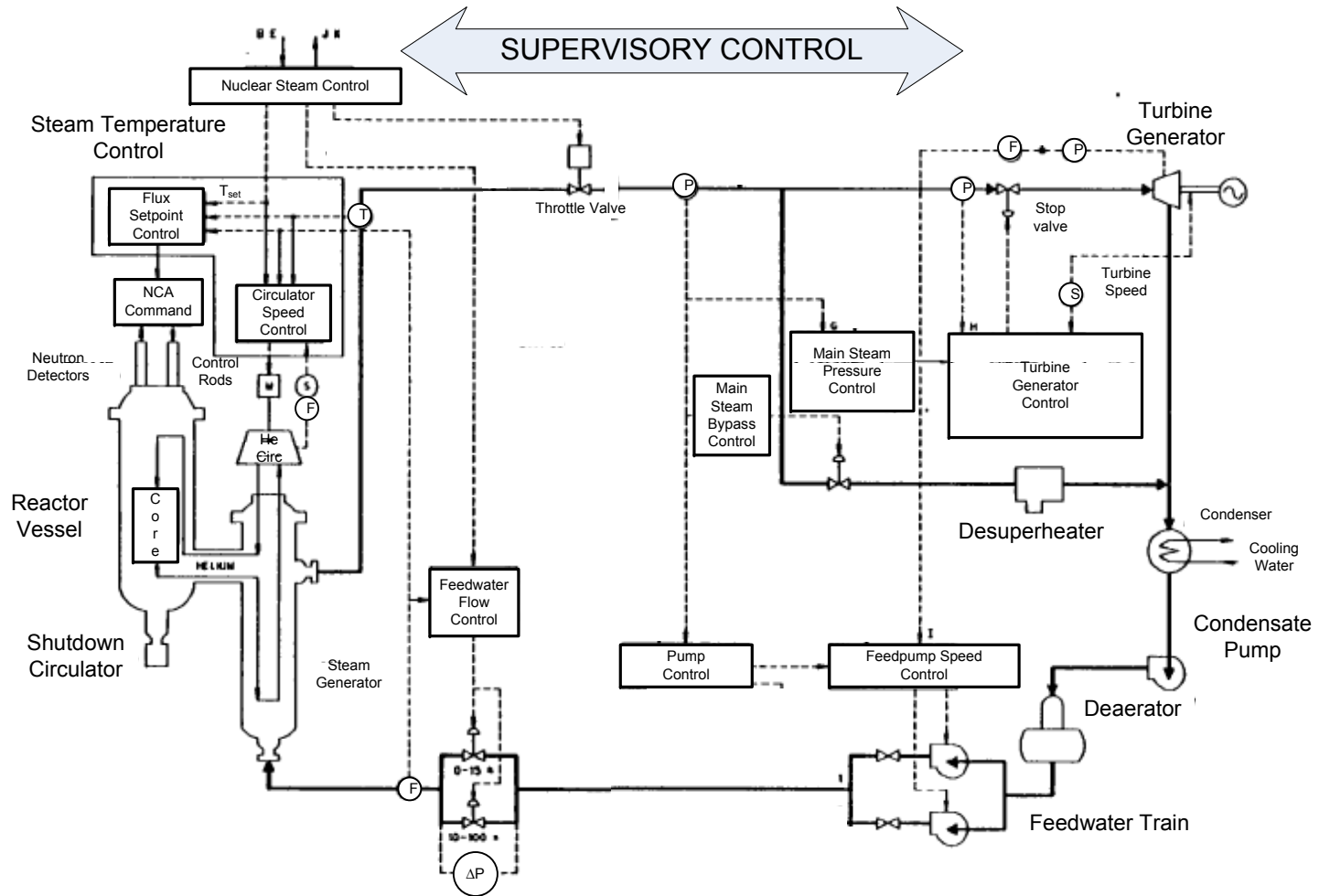

OUTLINE

- Control and protection systems included in I&C
- Reactor and process control in High Temperature Gas-Cooled Reactor (HTGR) plant designs
- ➔ • Application of digital systems to monitoring, control, and protection equipment
- Reactor protection developed in previous HTGR plants
 - I&C protection system functions and protection hardware interfaces
 - Reliability and interpretation of regulatory criteria
- **Control Room and I&C architecture preferred for overall operation of the HTGR and associated heat utilization processes**

Digital-Based I&C Architecture — Advantages Considered in 90's Era HTGR Designs

- **Modern digital displays optimize plant operation and supervision, and improve the human-machine interface**
 - Consoles, displays, etc can achieve greater detail, but also provide maximum overview and flexibility, thereby supporting plant operations more effectively.
- **Digital communication systems are better suited for multi-level information hierarchies, comprised of separated protection, control, and support networks, and can easily allow plant-wide distribution of instrumentation and command signals**
 - Better supports a **single Control Room** plant design

Digital-Based PCDIS, RPS and IPS Equipment was Selected for Modular HTGR I&C Designs

- **Supported single control room visibility and controllability of multiple reactor, multiple process plants**
 - Modern graphical operation interface was considered essential
- **Commercially proven, microprocessor based, distributed control hardware and operating software were available**
 - Reduced I&C development effort
- **Improved reliability**
 - Reduced wires, connections, and reliance on single points typical of 60s to 70s analog era

Digital Interfaces for Operator Control and Information were Investigated by 90s Era Simulation Techniques

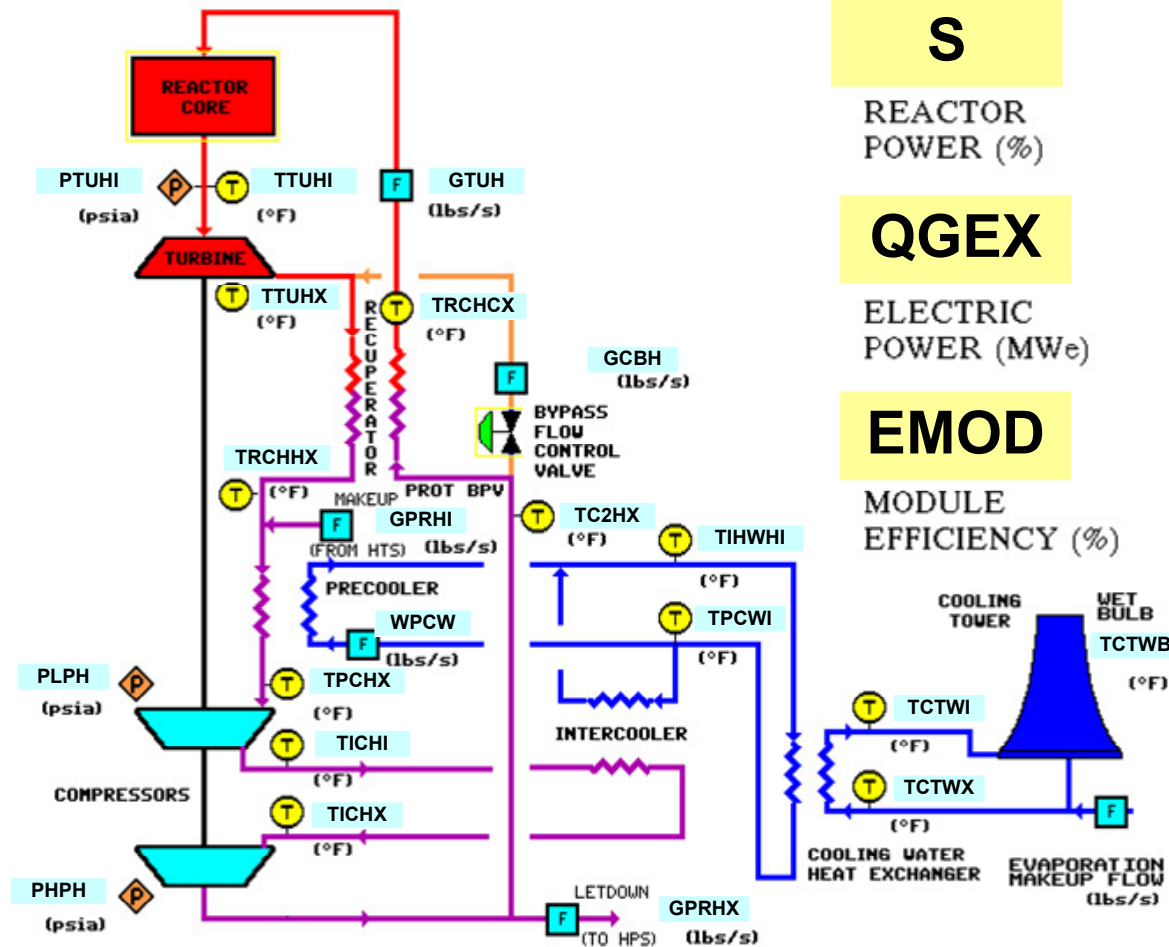

S

REACTOR POWER (%)

QGEX

ELECTRIC POWER (MWe)

EMOD

MODULE EFFICIENCY (%)

TOP LEVEL
REACTOR INFORMATION
POWER CONVERSION INFORMATION
SCS INFORMATION
RCCS INFORMATION
GENERATOR INFORMATION
TURBINE/COMPRESSOR INFORMATION
HEAT EXCHANGER INFORMATION
PREVIOUS
LEVEL
1 2
3 4

Recent Regulatory Criteria Support Digital I&C

- **Regulatory Guide 1.152 offers guidelines that can be applied to the HTGR design**
 - Contains criteria for use of computers in safety systems of nuclear power plants
 - Addresses software V&V, security from electronic vulnerabilities, use of commercial pre-developed I&C software and software development phases
- **Conversion from analog equipment to digital in existing plants may offer further information on application of the new guidelines**

OUTLINE

- Control and protection systems included in I&C
- Reactor and process control in High Temperature Gas-Cooled Reactor (HTGR) plant designs
- Application of digital systems to monitoring, control, and protection equipment
- ➔ • Reactor protection developed in previous HTGR plants
 - I&C protection system functions and protection hardware interfaces
 - Reliability and interpretation of regulatory criteria
- **Control Room and I&C architecture preferred for overall operation of the HTGR and associated heat utilization processes**

HTGR Reactor Protection Incorporates a Typical Strategy to Detect, Protect, and Provide Cooling

- **Detect an event which requires a reactor trip**
 - Events fall into various equipment failure categories. Design Basis Events (DBEs) are established for design of the protection system
- **Trip the reactor using safety-related equipment**
 - Gravity insertion of control rods. Backed up by Reserve Shutdown Control Equipment
- **When operable, use the main loop (ML) cooling functions to cool the reactor**
 - Incorporates Defense-in-Depth into the protection design strategy
- **When necessary, use shutdown cooling**
 - Active cooling systems are backed-up by the RCCS

Non-Safety Cooling Source in Events Requiring Reactor Trip

Plant Type	Event Description and Reactor Cooling Source (ML=main loop, SCS=Shutdown Cooling System)
All	Rapid, sustained control rod withdrawal (ML)
All	Slow, sustained control rod withdrawal (ML)
All	Operator or process trip (ML)
All	Loss of primary He flow or pressure (ML or SCS)
Steam-Electric	Loss of Off-site Power (LOSP) plus turbine protective action (ML) <u>Note:</u> The reactor continues to operate at reduced power, in the Gas Turbine HTGR following LOSP, and this can be designed into steam plants as well.
Steam-Electric	Steam Generator tube leak, loss of primary or secondary flow, loss of waste heat removal (SCS)

Protective Action Requires Detection, Reactor Trip, and Selection of a Cooling Sequence

- Protective action initiated by comparing measured levels with established levels (Set-Points)
- Additional protection system processing required to confirm and initiate a protective action

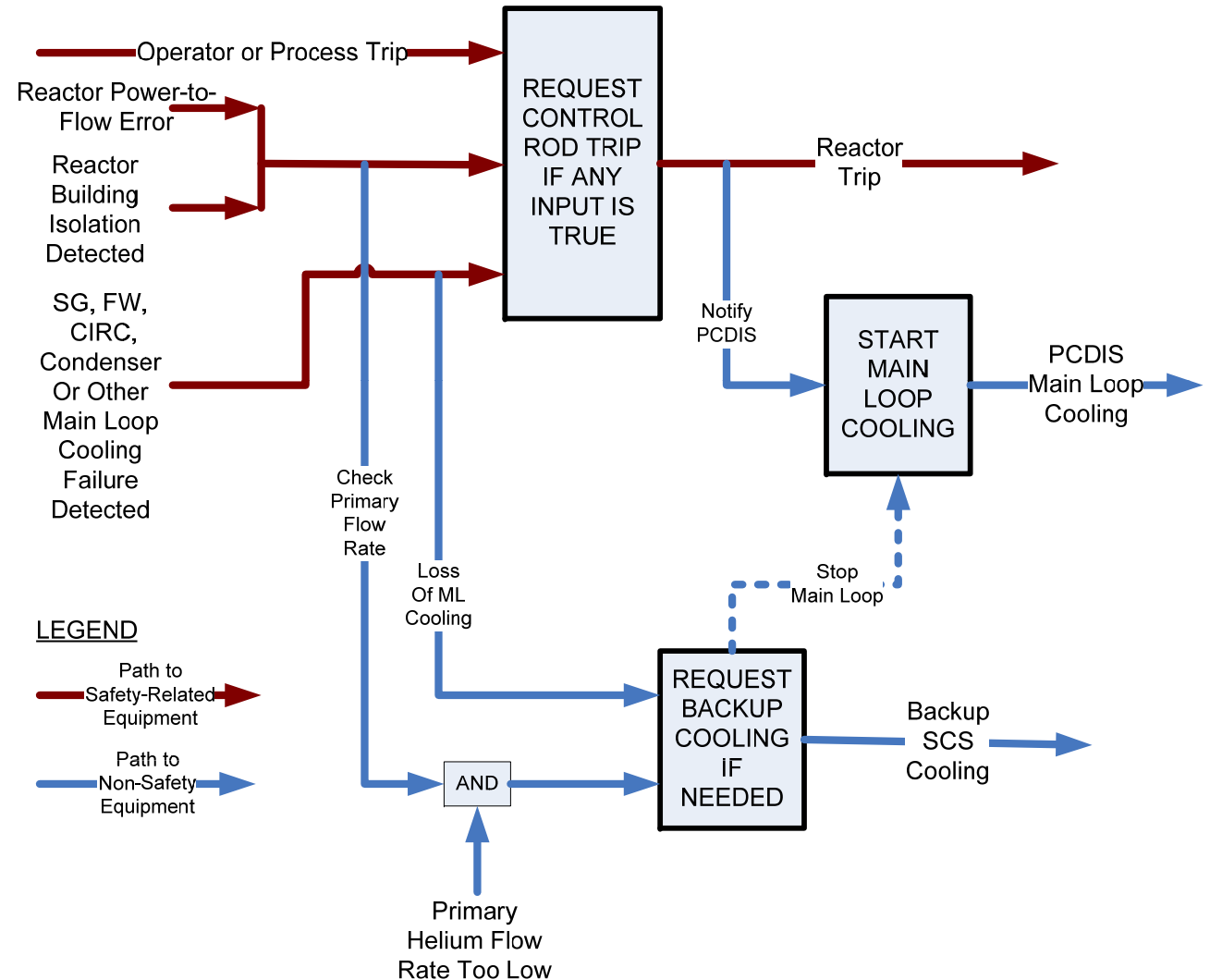

Typical Steam-Electric Plant Reactor Protection Set-Points and Measurements

Protection Set-Point Parameters	Physical Measurements Needed	System Providing Instrumentation (per I&C spec)
Reactor Power-to-flow ratio	Neutron flux/He flow	Reactor, Reactor building
Helium Flow Rate	Circulator P, T, Δp and Speed	Circulator
Reactor Exit/Inlet Helium Temps	He Supply/ Return Temp	Steam Generator/ Vessel
Turbine Status	Trip Signal	Balance of Plant
SG Boundary	He moisture content, Press	Steam Generator/ Vessel
SG Flow Rate	Feedwater flow	Balance of Plant

Instrumentation Estimates for a Steam-Electric Plant Provided in Preliminary NP-MHTGR Documentation

Significance of Measurements	Distribution of Measurements
Primary Reactor Operation supporting systems such as the Reactor, Shutdown Cooling, Helium Purification, Steam Generator, etc.	2500 measurements, distributed in 22 systems
Secondary instrumentation supporting plant operation in systems such as plant electrical, He transport & storage, rad monitoring, water treatment, etc	1500 measurements distributed in 19 systems

Protection System End-Action Method Typical in HTGR Protection Design

End-Action	Method Used	System Providing Hardware
Control Rod Trip	De-energize CR holding coils	Reactor – Neutron Control Assembly
Steam Generator Isolation	Activate SG Isolation & Dump	Steam Generator Vessel, BOP
Start Backup Cooling	Shutdown main circulator and start SCS	Shutdown Cooling System (SCS)
SCHE Isolation and Drain	Close SCHE Isolation valves. Open SCHE drain	Shutdown Cooling System (SCS)

HTGR Protection Equipment Design Criteria Have Been Established — Fort St. Vrain Experience was Important

- **Protection systems incorporate 2 out of 4 logic to provide redundancy**
 - This strategy reverts to 2 out of 3 logic to support on-line maintenance and testing
- **All protection systems use the same design strategy and use Class 1E equipment**
 - Highest qualification is required for “safety-related” equipment — important criteria determined by specific plant location and design
 - Inherent safety features of the HTGR allow lesser requirements for investment protection equipment not directly associated to public safety

2 out of 4 Logic Provides Redundancy but Prevents Spurious Trips

- Decision logic compares data to set-point
- Coincidence logic confirms that 2 of the same trips — of 4 possible — have been requested, and allows either the A or B trip train to activate the hardware

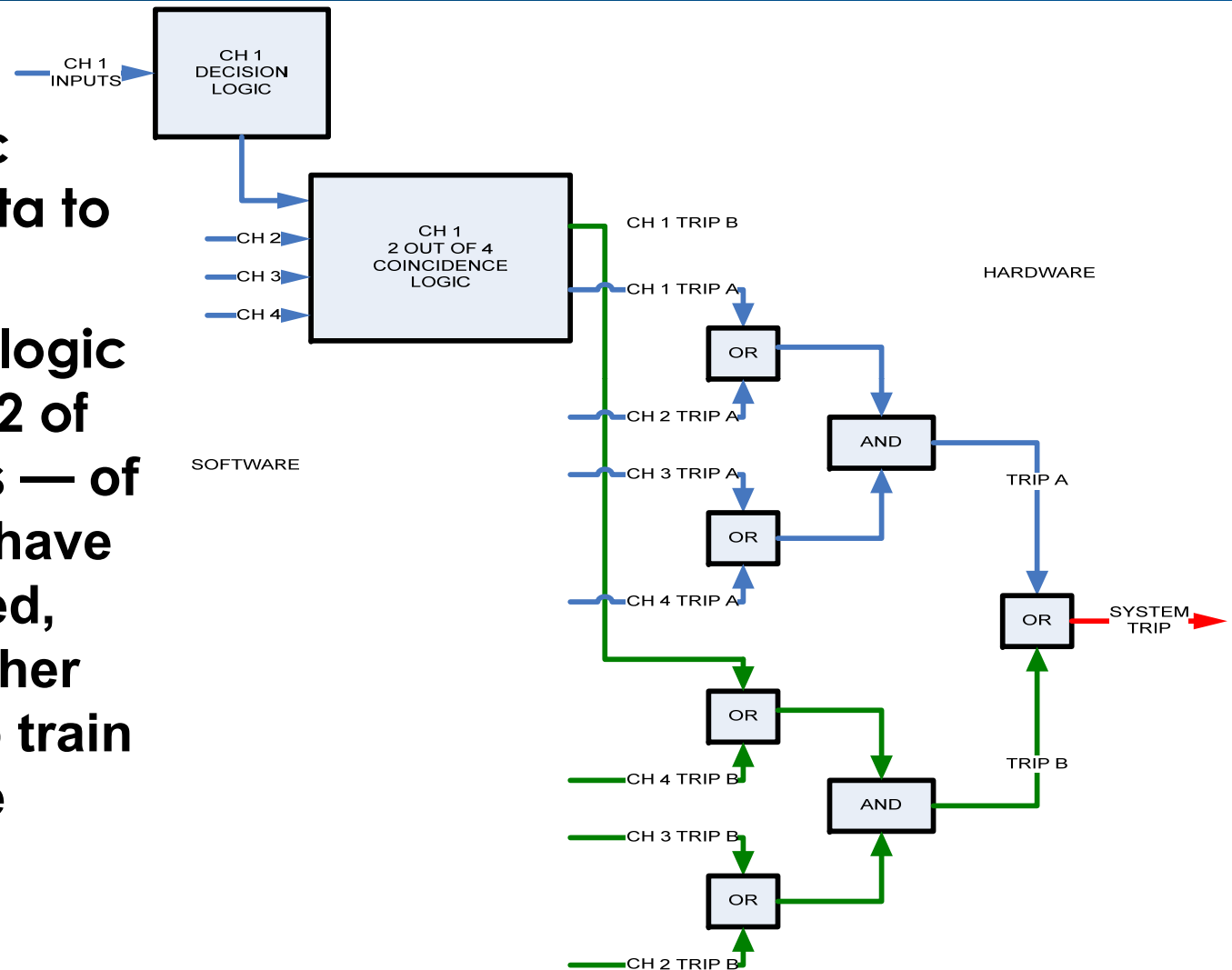

Basis for 10CFR50 Design Criteria Incorporated in HTGR I&C Systems

- **10 CFR 50.55a(h)**
 - Addresses the design of I&C systems performing safety functions
 - Incorporates IEEE 603/IEEE 279 describing design bases for reliability, independence, single failures, qualification, HMI considerations, displays, status indication, testing, operating and maintenance bypasses, setpoints, etc
- **LWR General Design Criteria (GDC) in Appendix A of the Code of Federal Regulations (CFR), Title 10, Part 50**
 - Address design, implementation, construction, testing, and performance requirements
 - Apply to structures, systems, and components important to safety.
- **Appendix B of 10 CFR 50 establishes Quality Assurance (QA) requirements**

Additional Considerations Affecting Protection and Control Design in HTGR Plants

- **Inclusion of Safety-Related electric supply systems**
- **Specific separation, diversity, and QA requirements for safety Instrumentation, data processing systems, decision logic processors, etc.**
- **Sharing of safety-related hardware to perform automatic control as well as reactor protection actions**
- **Provision of dedicated safety consoles, displays and procedures for real-time information, warnings, alarms, and operator initiated protective actions**
 - May include remote shutdown.
- **Achievement of specific levels of reliability for all instrumentation, control, and supporting equipment affecting overall operability and plant operating goals.**

Outline

- **Control and protection systems included in I&C**
- **Reactor and process control in HTGR plant designs**
- **Application of digital systems to monitoring, control, and protection equipment**
- **Reactor protection developed in previous HTGR plants**
 - I&C protection system functions and protection hardware interfaces
 - Reliability and interpretation of regulatory criteria
- ➔ • **Control Room and I&C architecture preferred for overall operation of the HTGR and associated heat utilization processes**

Conclusions Reached in HTGR Plant Designs Specifying Operation from a Single Control Room

- **Various trade studies conducted by participants in the NP-MHTGR and the MHTGR programs concluded:**
 - Supervision and communication aspects are greatly improved
 - Plant operation activities, including maintenance and process observation are better supported
 - Staffing and design costs are lower
- **Use of modern computer technology provided an essential space-saving feature, supportive of an advanced operator interface within a single control room**

The Four Reactor NP-MHTGR Plant Design Provided Typical HTGR Control Room Design Strategies

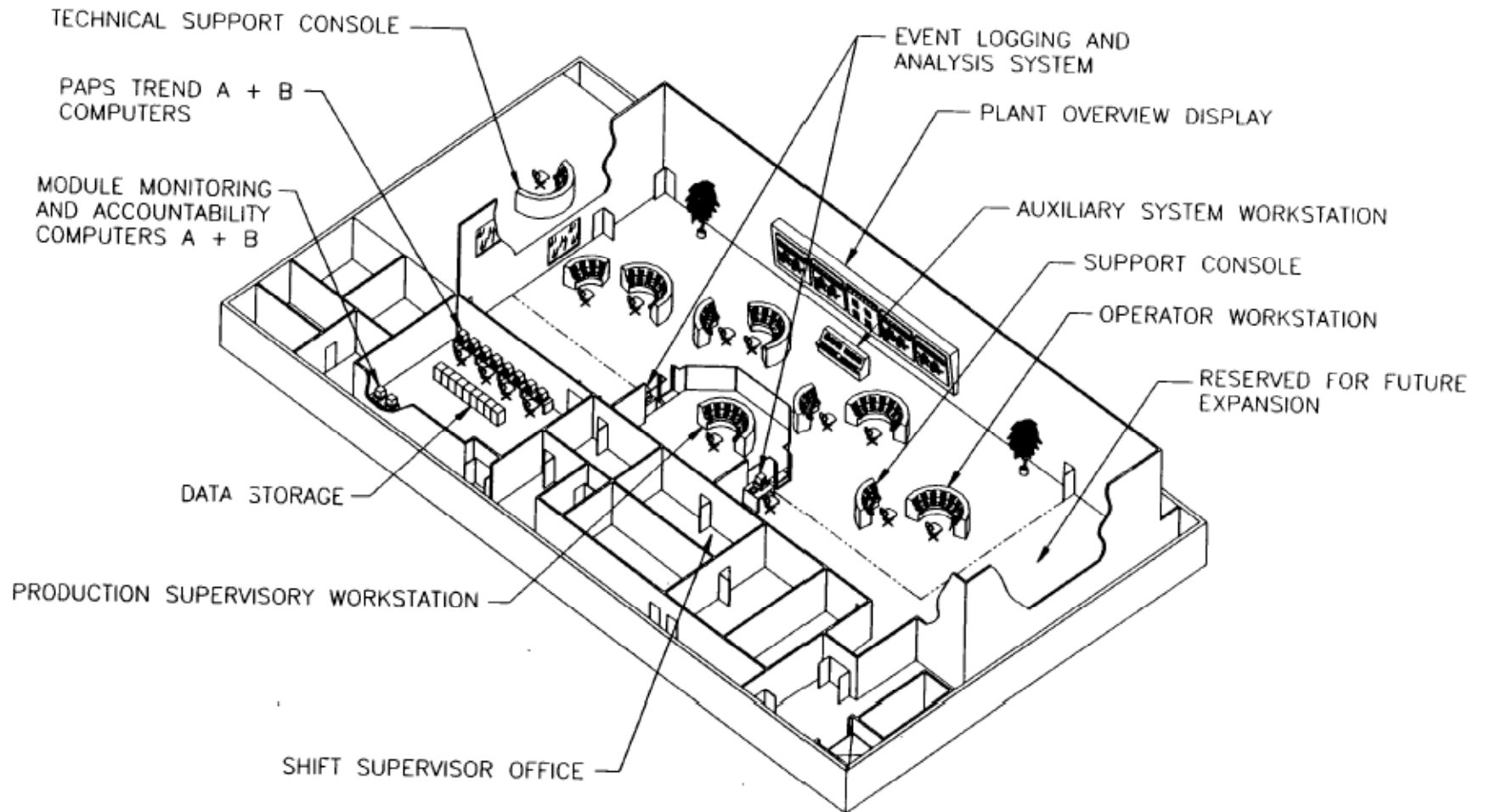

Multiple Levels of Data Transfer Hierarchy in 90's Era Design Typify the Need for Modern Networking Features

- Plant wide data highways support supervision, maintenance and plant information processing
- Intermediate level data highways exchange instrumentation and control signals
- Lower level data highways exchange information to specific plant areas

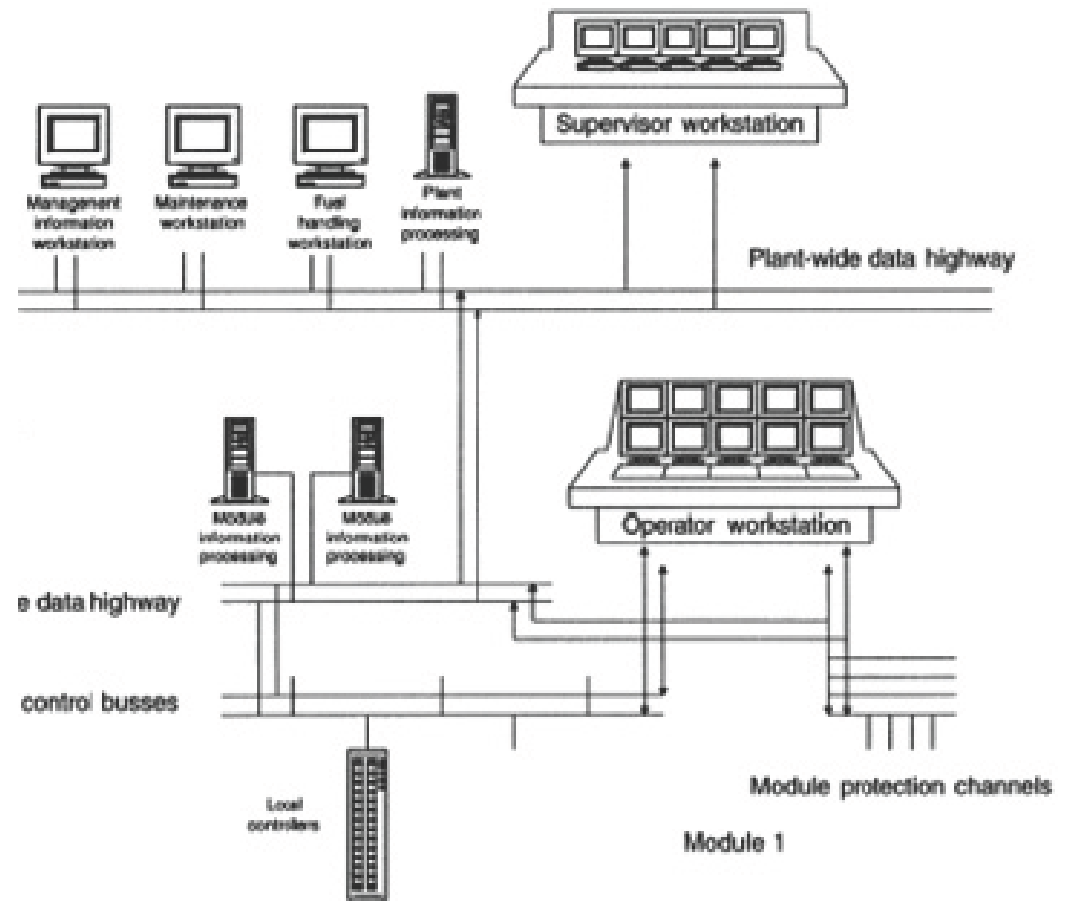

Digital Architecture Provides Separation of I&C Systems While Providing Total Information for All Operators

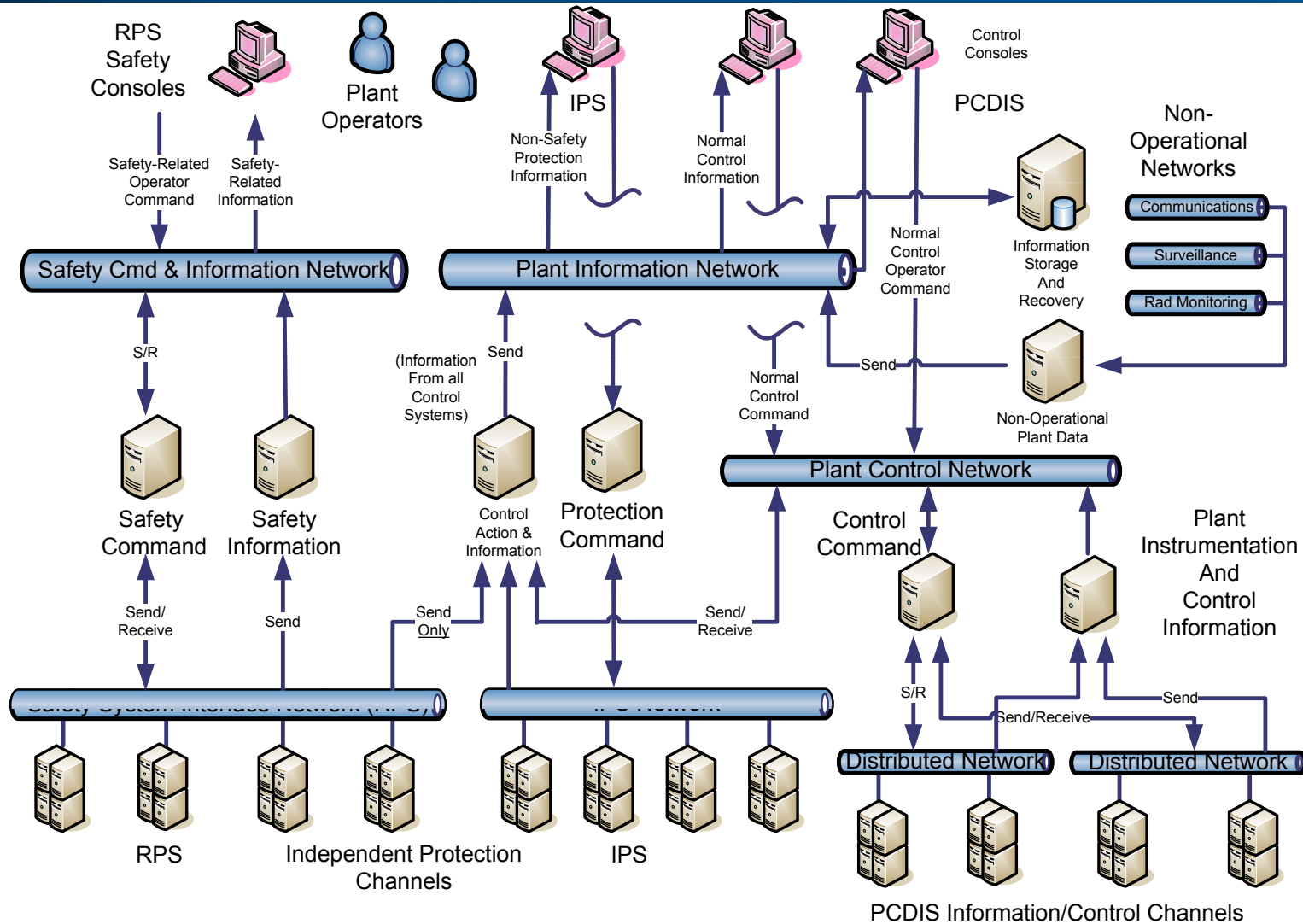

Summary

- **I&C provides monitoring and control all plant processes, and incorporates strategies to enhance reactor safety, equipment protection, and plant operability**
- **Modern digital equipment is expected to form the basis of the various I&C components, including safety systems**
- **The I&C design is aided by past HTGR programs which have developed documentation, inter-system responsibilities, methods, analysis, and testing needs for I&C design**
- **The plant architecture provides a multi-level information hierarchy, allowing plant-wide distribution of instrumentation and command signals, and access to all plant functions from a single control room**

Suggested Reading

- **DOE-HTGR-86004, Overall Plant Design Specification Modular High Temperature Gas-Cooled Reactor**
- **DOE-HTGR-86076, Plant Control, Data and Instrumentation System**